

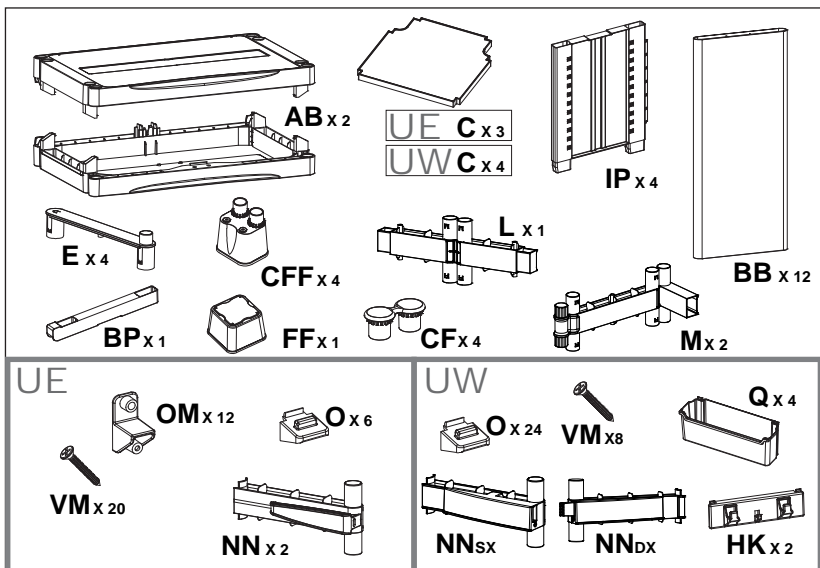

3700

UE
UW

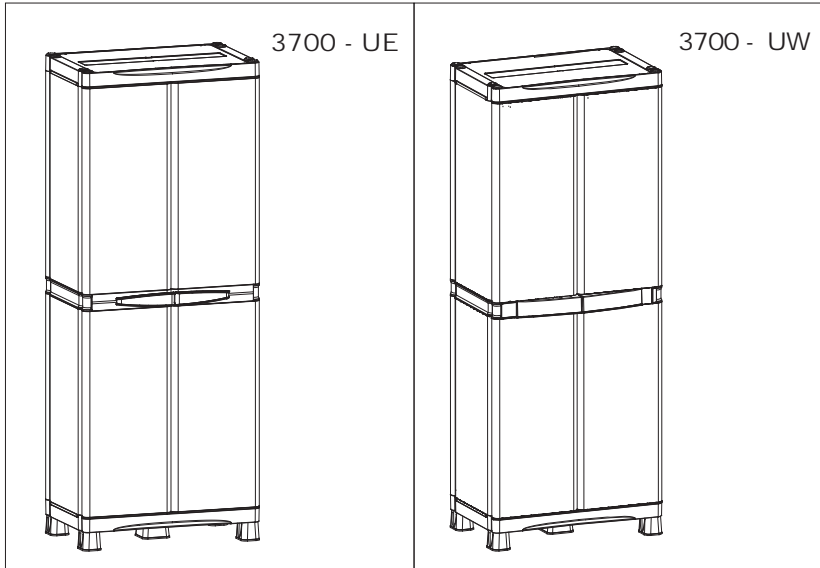

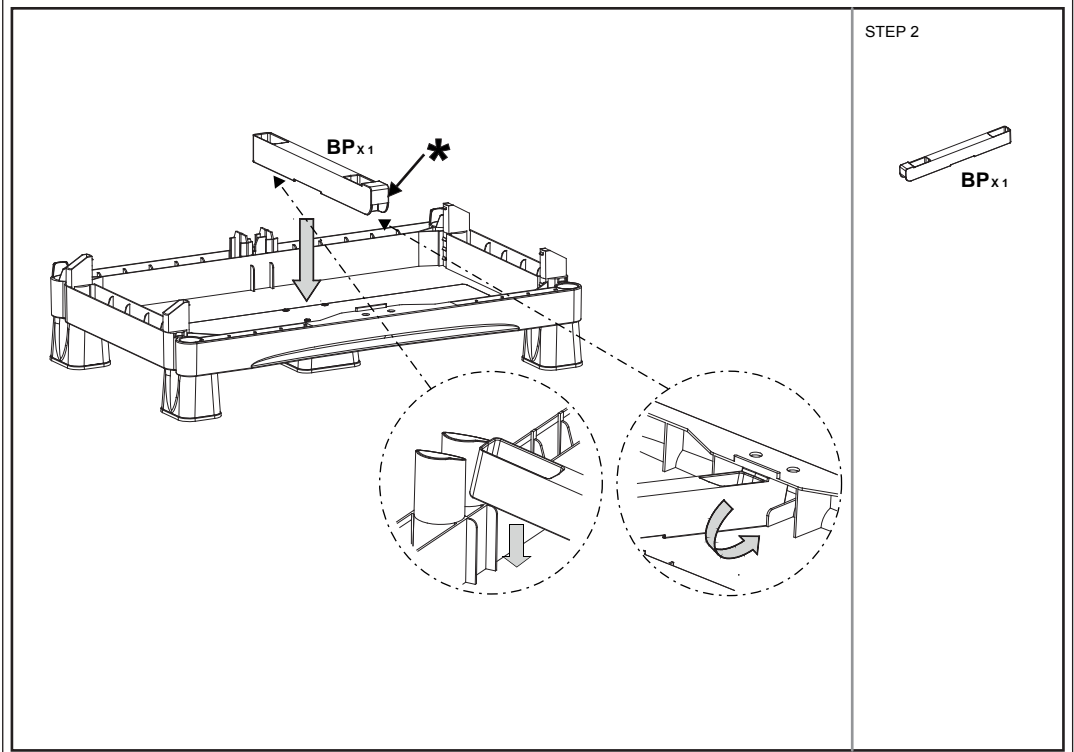
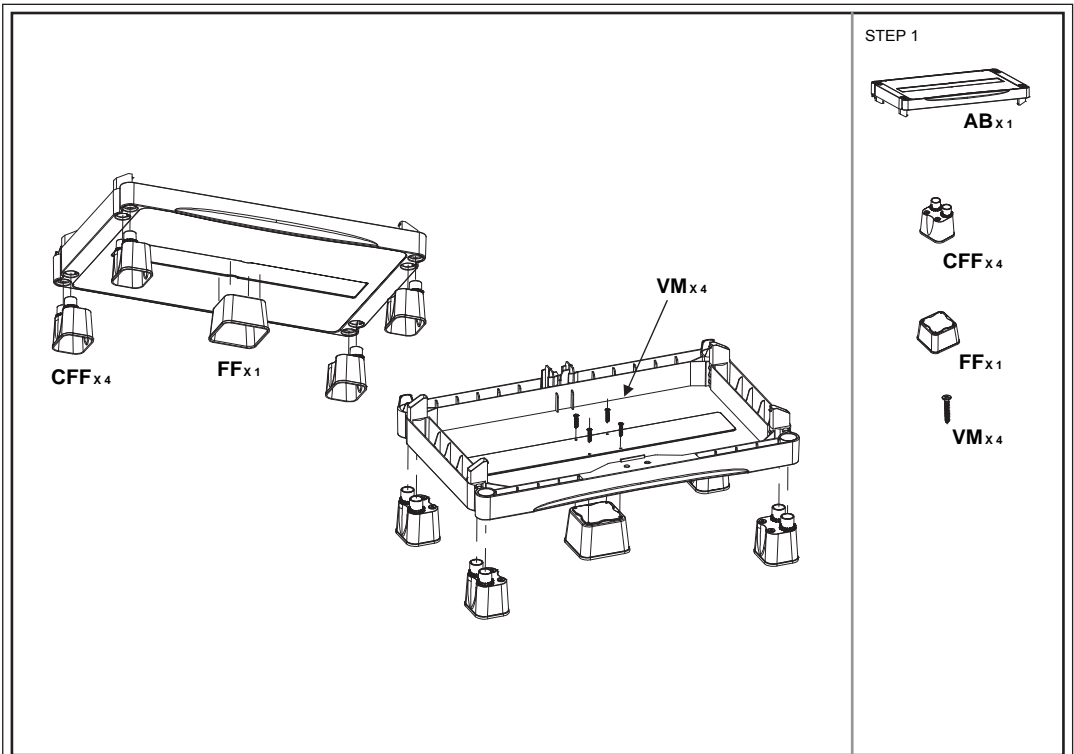

STEP 3

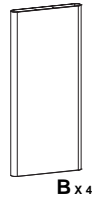
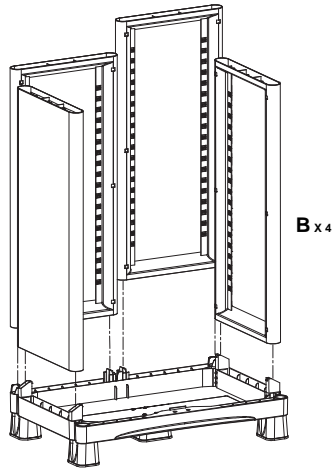

STEP 4

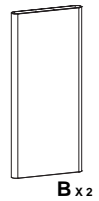
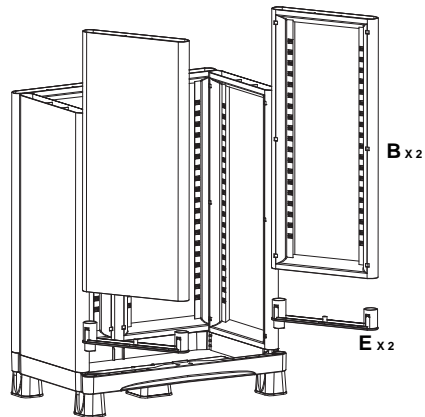

STEP 5

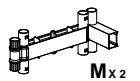
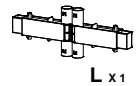
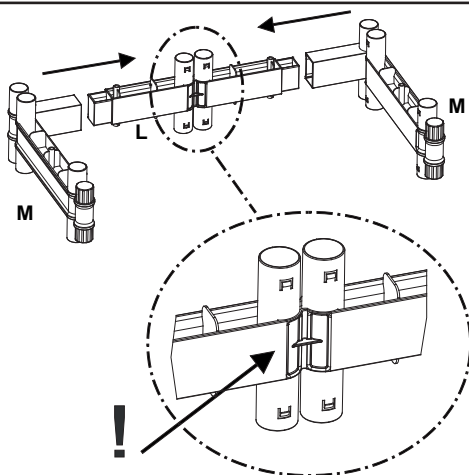

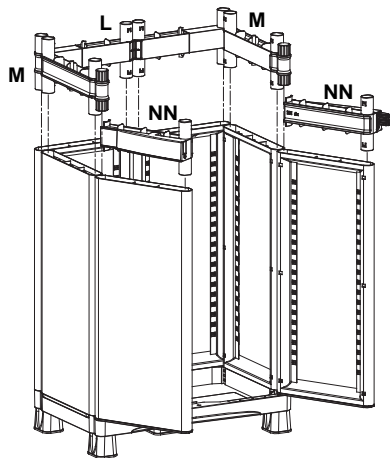

STEP 6

UW

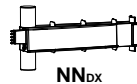

NNdx

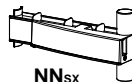

NNsx

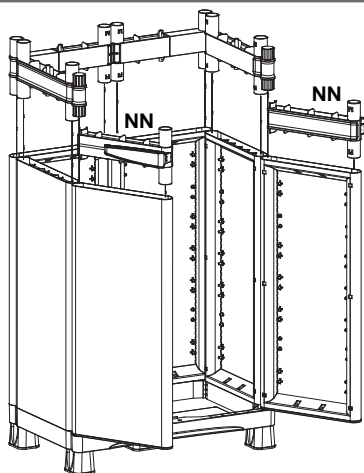

STEP 6

UE



NN x2

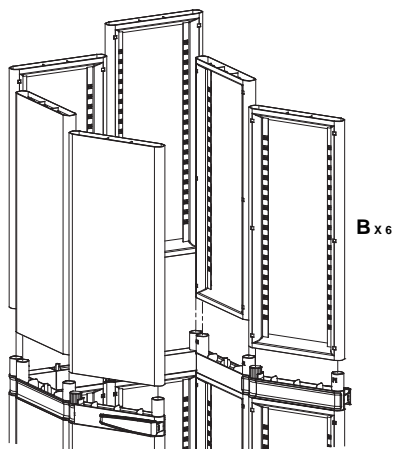

STEP 7



B x6

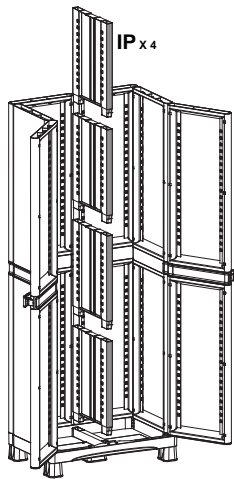

STEP 8

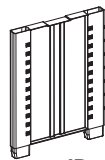

IPx4

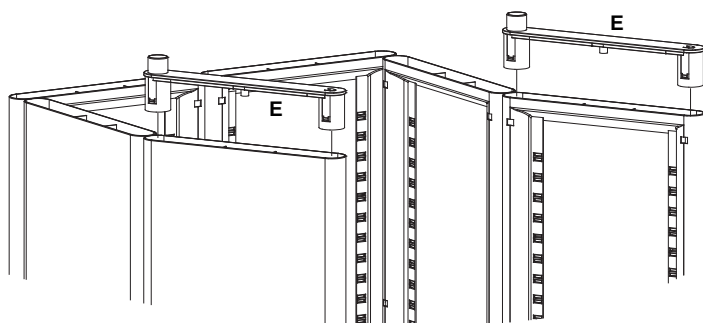

STEP 9

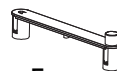

E x2

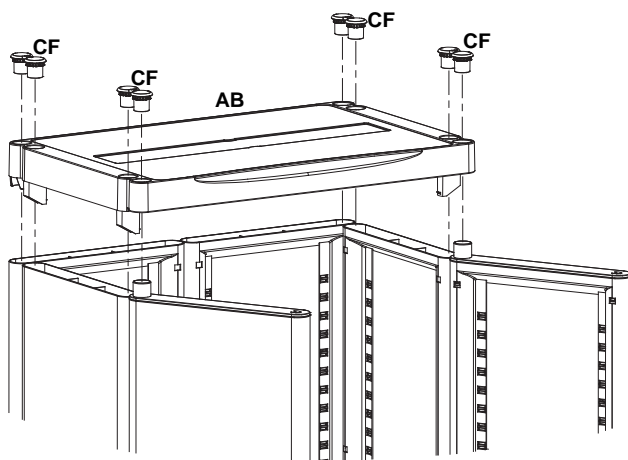

STEP 10



AB x1



CF x4

STEP 11

UW

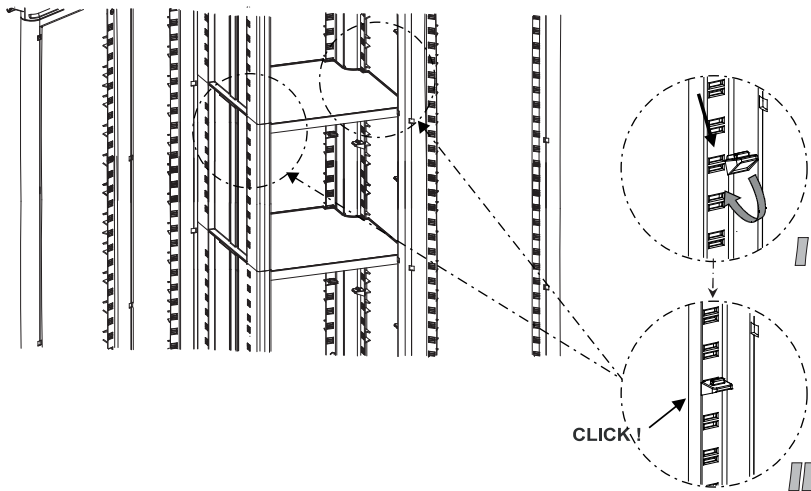

STEP 11

UE

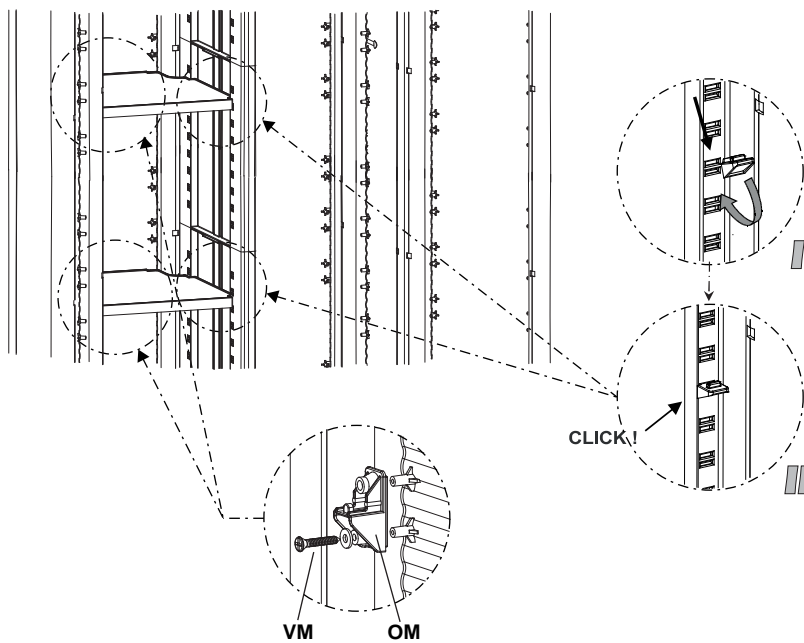

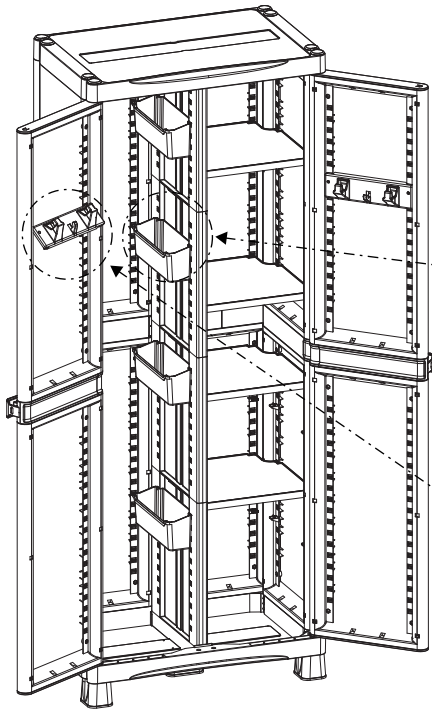

STEP 12

UW

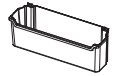

Q x 4

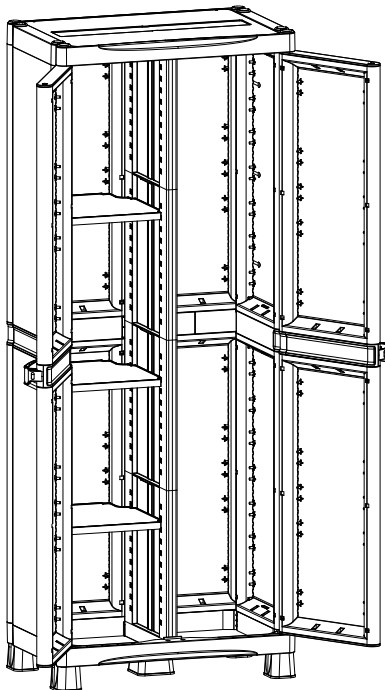
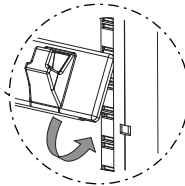
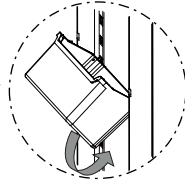

STEP 12



UE

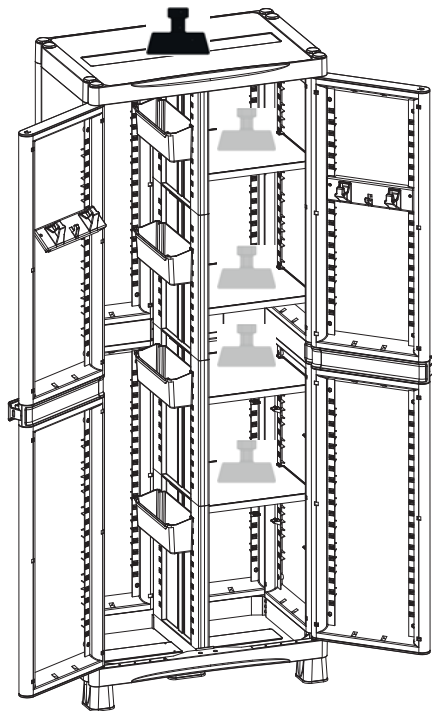

UE



UW

 **Kg./Lbs 15/33**
 **Kg./Lbs 20/44**

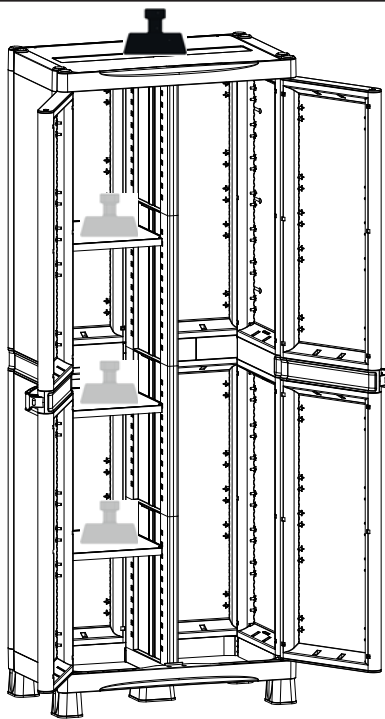

UE

 **Kg./Lbs 15/33**
 **Kg./Lbs 20/44**

A1



Rs x2 

Vs x2 

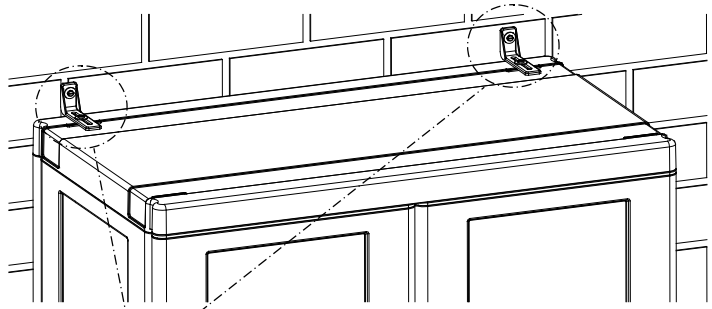

Vs

Rs



* NOT INCLUDED

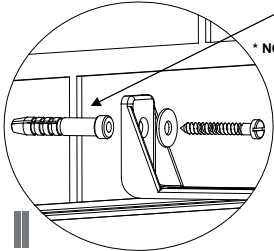
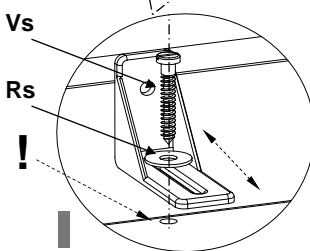

Utilizzare le viti "Vs" e le rondelle "Rs" in dotazione per fissare la squadretta "Sts" al tettuccio dell'armadio (fig I). Successivamente fissare la squadretta "Sts" alla parete (fig II). Per il fissaggio al muro utilizzare viti* e tasselli* adeguati alla tipologia di parete a disposizione * NOT INCLUDED

A2



Rs x2 

Vs x2 

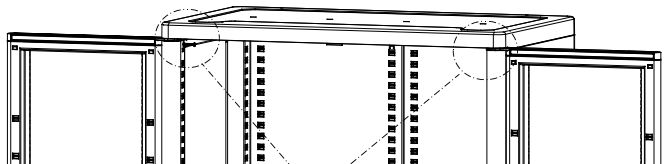
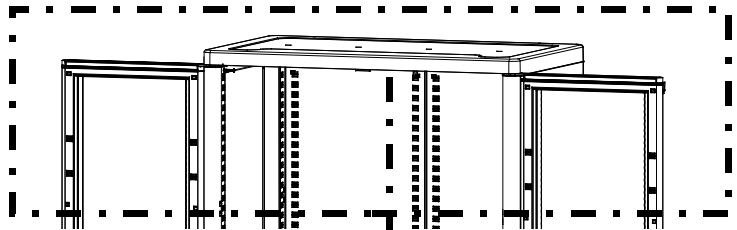

Rs

Vs



Precauzioni di sicurezza

Utilizzare le viti "Vs" e le rondelle "Rs" in dotazione per fissare la squadretta "Sts" al tettuccio dell'armadio (fig I). Successivamente fissare la squadretta "Sts" alla parete (fig II). Per il fissaggio

al muro utilizzare viti* e tasselli* adeguati alla tipologia di parete a disposizione

Security precautions

The cabinet shall be fixed to the wall

By using the supplied screws "Vs" and friction rings "Rs", fix the bracket "Sts" to the top of the cabinet (Fig. I). Then fix the bracket "Sts" to the wall (Figure II) using screws and wall plugs suitable to your wall

Précautions de sécurité

L'armoire doit être fixée au mur

Utilisez les vis « VS » et les rondelles « RS » en dotation pour visser l'équerre « STS » sur le dessus de l'armoire (image 1). Après, fixez l'équerre « STS » au mur (image II). Pour la fixation murale utilisez les vis et les équerres en fonction de la nature du mur à votre disposition.

Sicherheitsvorkehrungen

Der Schrank muß an der Wand befestigt werden

Verwenden Sie die gelieferten Schrauben " Vs " und die Unterlegscheiben " Rs " um die Klammer « Sts » auf dem Deckel des Schrankes zu befestigen (Abbildung 1). Danach befestigen Sie die Klammer « Sts » an der Wand. Für die Wandfixierung benutzen Sie ausreichende Schrauben und Dübel je nach der Wandart die zur Verfügung steht.

Precauciones de seguridad

El armario debe ser fijado a la pared

Utilizar las vides "Vs" y las rondanas en dotación para fijar el escuadra "Sts" a la cima del armario (fig I). Después fijar el escuadra "Sts" a la pared (fig II). Por el fijado al muro utilizar vides y tacos en función de la tipología de la pared a vuestra disposición.

Precauções de Segurança

O gabinete é fixado à parede

Use os parafusos "Vs" e arruelas "Rs" fornecida para fixar o suporte "santos" para o teto do gabinete (Fig. I). Em seguida, anexar o suporte de "Sts" para a parede (Fig. II). Para fixação parede usando parafusos e buchas adaptadas para os tipos disponíveis

Środki ostrożności

Obudowa jest mocowana do ściany

Użyj śruby "Vs" i podkładki "Rs" dostarczone do mocowania uchwytu "Świętych" na dachu szafy (rys. I). Następnie podłącz wspornik "Sts" do ściany (rys. II). Do mocowania na ścianie za pomocą śrub i kołki dostosowane do rodzajów dostępna

Προφυλάξεις Ασφαλείας

Το υποουγκικό συμβούλιο στερεώνεται στον τοίχο

Χρησιμοποιήστε τις βίδες "Vs" και ροδέλες "Rs" που παρέχεται για τη στερέωση του βραχίονα "Sts" στην οροφή της καμπίνας (Σχήμα I). Στη συνέχεια, συνδέστε το στήριγμα "Sts" στον τοίχο (Σχήμα II). Για τον καθορισμό των τοίχο με βίδες και ούπα προσαρμόζονται στους τύπους διαθέσιμων

Varnostni ukrepi

Omarica je pritrjena na steno

Uporabite vijake "Vs" in podložke "Rs", ki za pritrditev oklepaj "Sts", na streho kabineta (slika I). Potem pritrdite nosilec "Sts", na steno (slika II). Za pritrjevanje na zid z vijaki in zidne vložke prilagodijo glede na vrsto razpoložljivih

Bezpečnostní opatření

Skříň je připevněn ke zdi

Použijte šrouby "VS" a podložky "Rs", dodává k upevnění držáku "Sts" na střechnu skříně (obr. I). Poté připojte konzolu "Sts" na stěnu (obr. II). Pro upevnění na stěnu pomocí vrutů a hmoždinek přizpůsobit dostupné typy

Bezpečnostné opatrenia

Skriňa je pripevnený k stene

Použite skrutky "VS" a podložky "Rs", dodáva na upevnenie držiaku "Sts" na strechu skrine (obr. I). Potom pripojte konzolu "Sts" na stenu (obr. II). Pre upevnenie na stenu pomocou skrutiek a hmoždiniek prispôsobit' dostupné typy

Turvallisuusohjeet

Kaappi kiinnitetään seinään

Käytä ruuveja "vs" ja aluslevyt "Rs" toimitetaan kiinnitä asennuslevy "Sts" sen katolle kaapin (kuva I). Sitten levyyn "Sts" seinään (Kuva II). Kiinnittämiseen seinään ruuveilla ja seinätulpat mukautetaan kulloiseenkin käytettävissä

Atsargumo priemonės

Spinta tvirtinama prie sienos

Naudokite varžtus "VS" ir poveržlės "RS" tiekiamos pridėti laikiklis "Sts" į kabinetą stogo (pav. I). Tada pridėti laikiklis "Sts" prie sienos (pav. II). Tvirtinimo prie sienos naudojant varžtus ir sienų kaiščius pritaikytas tipais

Sikkerhedsforanstaltninger

Kabinettet er fastgjort til væggen

Brug de skruer "Vs" og skiver "RS" leveres til at fastgøre beslaget "Sts" på taget af kabinettet (figur I). Sæt derefter beslaget "Sts" til væggen (figur II). Til montage på væggen med skruer og rawlplugs tilpasset de typer til rådighed

Măsuri de siguranță

Cabinetul este fixat pe perete

Folosiți șuruburi "Vs" și șaibe "Rs", furnizate pentru a atașa suportul "Sts" la acoperiș a dulapului (figura I). Apoi atașați suportul "Sts" la perete (Figura II). Pentru fixarea pe perete cu șuruburi și prize de perete adaptate la tipurile disponibile

Güvenlik Önlemleri

Kabine duvara bağlanır

Vidaları "Vs" ve pullar kabine çatıya destek "Sts" eklemek için verilen "Rs" (Şeki I) kullanın.

Daha sonra duvar (Şekil II) dirsek "Sts" ekleyin. Vida ve duvar kullanarak duvara sabitlemek için türleri mevcut adapte fişler

Säkerhetsföreskrifter

Skåpet fästs i väggen

Använd skruvarna "Vs" och brickor "Rs" som medföljer för att fästa konsolen "Sts" på taket på skåpet (Figur I). Sedan fäster fästet "Sts" på väggen (Figur II). För montering på väggen med skruvar och pluggar anpassas till de typer som finns

Veiligheidsmaatregelen

Het kabinet is bevestigd aan de muur

Gebruik de schroeven "Vs" en ringen "Rs" geleverd aan de beugel "Sts" hechten aan het dak van de kast (zie figuur I). Bevestig vervolgens de beugel "Sts" tot de wand (figuur II). Voor de vaststelling van de muur met schroeven en pluggen aangepast aan de beschikbare types

Sikkerhetskensyn

Skapet er festet til veggen

Bruk skruene "Vs" og skiver "Rs" medfølgende å feste braketten "Sts" på taket av kabinettet (figur I). Fest deretter braketten "Sts" til veggen (figur II). For å feste på veggen med skruer og pluggar tilpasset de typer tilgjengelig

Biztonsági óvintézkedések

A szekrény rögzítése a falra

A csavarokat "Vs" és alátétek "Rs" szállított csatolja a konzol "Sts" a tető a szekrény (I. ábra). Ezután csatlakoztassa a konzol "Sts" a falra (ábra II.) Rögzítéséhez a falra csavarokat és tipliket igazítani a típus kapható

Мерки за безопасност

Кабинетът се закрепва към стената

Използвайте винтове "Vs" и шайби "Rs" доставени за закрепване на скоба "Sts" на покрива на кабинета (фиг. I). След това приложете на скоба "Sts" на стената (фиг. II). За закрепване на стена с винтове и дюбели адаптират към вида на разположение

Drošības pasākumi

Kabinets ir piestiprināts pie sienas

Izmantojiet skrūves "Vs" un paplāksnes "Rs" piegādāja pievienot grupā "Sts", lai jumta kabinets (attēls I). Tad pievienojiet grupā "Sts", lai sienas (attēls II). Fiksēšanai pie sienas, izmantojot skrūves un sienu tapas pielāgoti veida pieejama

Ettevaatusabinõud

Kapis on seinale kinnitatud

Kasutage kruvisid "Vs" ja pesurid "Rs" tarnitud lisada sulg "Sts", et katusele ruumi (joonis I). Siis lisada sulg "Sts" seina külge (joonis II). Fikseerimiseks seinale kruvide ja seina pistikud kohandatud liiki saadaval